

TELESCOPIC RAIL

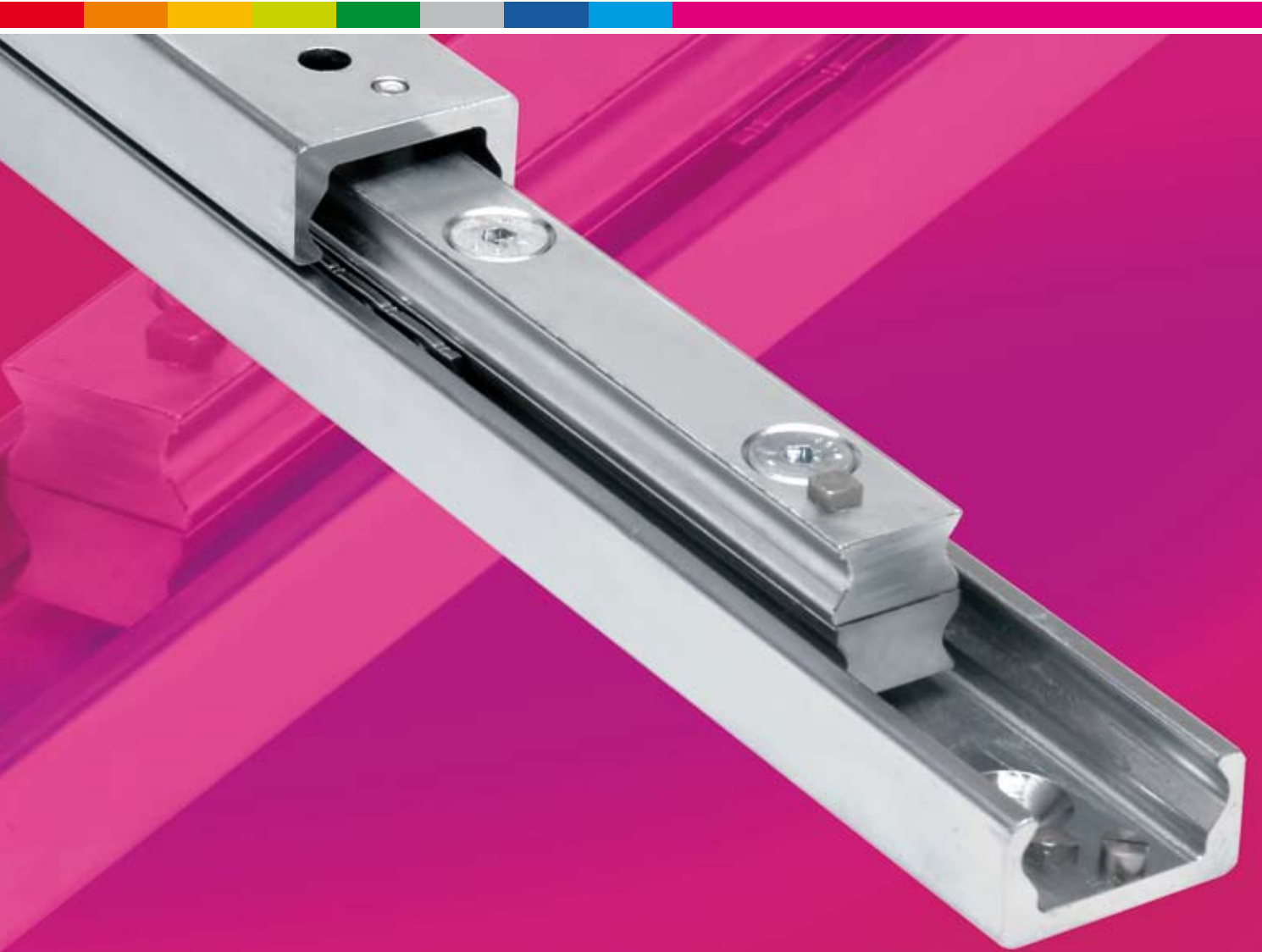

About Rollon



Development of global business

- 1975** Parent company, Rollon S.r.l., founded in Italy
- 1991** Founding of Rollon GmbH in Germany
- 1995** Expansion of headquarters to new 4,000 m² factory
Assembly starts in Germany
Quality management certified to ISO 9001
- 1998** Rollon B.V. in the Netherlands and Rollon Corporation in the USA are founded
Expansion of German branch to new 1,000 m² plant
- 1999** Founding of Rollon S.A.R.L. in France
Environmental management certified to ISO 14001
- 2000** Rollon s.r.o. founded in Czech Republic
- 2001** Expansion of headquarters to new 12,000 m² manufacturing plant
- 2007** Restructuring of the GmbH and alignment of production in Germany to customer-specific adaptations
Takeover of the assets of a manufacturer of linear rail systems
- 2008** Expansion of sales network in Eastern Europe and Asia

Continual expansion and optimization of the portfolio

Founded in 1975, Rollon manufactured high-precision linear roller bearings for the machine tool industry. Early on, Rollon started manufacturing linear bearings based on the bearing-cage design. In 1979, the Compact Rail self-aligning linear bearings joined the Telescopic Rail industrial drawer slides and Easy Rail linear bearings and became the basis of the strong foundation on which the company is building upon today. Continuing optimization of these core products still remains one of the most important goals at Rollon. The development of the patented Compact Rail linear bearing, which uses different proprietary rail profiles and high-precision radial ball bearing sliders, enables the compensation of height and angle mounting defects in applications, and is only one example of the continuing efforts to innovative the development of our existing product families. In the same manner, we continually introduce innovative new product families displaying our continuing product development and optimization in the industry. These include:

- 1994 Light Rail - full and partial extension telescopic in lightweight design
- 1996 Uniline - belt driven linear actuators
- 2001 Ecoline - economical aluminum linear actuators
- 2002 X-Rail - inexpensive formed steel linear guides
- 2004 Curviline - curved monorail profile rail guide with roller carriages
- 2007 Monorail - miniature sizes and full sized

Each further innovation of our linear bearings is built upon the our extensive knowledge of the nine product families in production today as well as on the current market demands. Rollon is the ultimate linear technology for any application needs.

Content

1 Product explanation	
Structural shapes and designs	4
2 Technical data	
Performance characteristics and remarks	7
3 Product dimensions	
ASN	8
DS	12
DE	17
DBN	20
LTF	23
DMS	25
DRT	27
4 Technical instructions	
Selection of telescopic rail, Load capacities	29
Deflexion	30
Static load	31
Service life	32
Speed, Extension and extraction force,	
Double-sided stroke, Temperature	35
Anticorrosive protection, Lubrication	36
Fixing screws	37
Installation instructions	38
Ordering key	
Ordering key with explanations and special strokes	
Portfolio	

Product explanation

Telescopic Rail: Seven models with full and partial extension



Fig. 1

The Telescopic Rail product line is made up of seven models with full and partial extension and various cross-sections and intermediate elements in S-shape, double-T or square. High loads in combination with cost-efficiency and free movement have long been the outstanding properties of the Telescopic Rail product line.

The most important characteristics:

- High loading with low deflexion
- Rigid intermediate elements
- Standardised gauge for holes
- Zero-play running even with maximum load
- Space saving design
- High reliability

Preferred areas of application of the Telescopic Rail product family:

- Railcars (e. g. maintenance and battery extensions, doors)
- Construction and machine technology (e.g., housings and doors)
- Logistics (e.g., extensions for containers or gripper movements)
- Automotive technology
- Packaging machines
- Beverage industry
- Special machines

ASN

Partial extension consisting of a guide rail and a slider. This compact size and simple design allow very high load capacities. The high system rigidity is formed here in connection with the adjacent construction.



Fig. 2

DS

Full extension consisting of two guide rails made of fixed and movable element and an S-shaped intermediate element. This has a high moment of inertia and high rigidity with slim size. This results in a high loading capacity with low deflexion in the extended state.

The DS series is available in three different designs: Version S with one-sided extension (DSS), Version B with locking in the extracted state for one-sided extension (DSB) and Version D with double-sided extension (DSD).



Fig. 3

DE

Full extension consisting of two guide rails, which together, combined as double-T profile, form the intermediate element, and two sliders, which as fixed and movable element form the connection to the adjacent construction. The square cross-section allows a compact size with high load capacities and low deflexion, especially with radial loading. A custom design is available for extensions with double-sided strokes. The simultaneous movement of the intermediate element is implemented with a driving disc.



Fig. 4

DBN

Full extension consisting of two guide rails, which are both fixed and movable element, and two sliders which together form the intermediate element. The size is similar to the DE series and offers good protection from dirt of the open ballcage.



Fig. 5

LTF

Full extension consisting of two guide rails as fixed and movable element and an S-shaped intermediate element. This special shape allows an extremely slim and compact design for movements that are only occasionally executed.



Fig. 6

DMS

Heavy load telescopic consisting of elements from the ASN series and an extremely rigid double-T profile as intermediate element. This full extension is used to accept the heaviest loads with low deflexion.



Fig. 7

DRT

Full extension on a roller slide base consisting of the S-shaped intermediate element from DS series and elements of the proven Compact Rail roller slider system. The use of roller sliders instead of a linear bearing as a load accepting element enables a larger resistance against contamination and an extremely quiet running of the full extension.



Fig. 8

Technical data

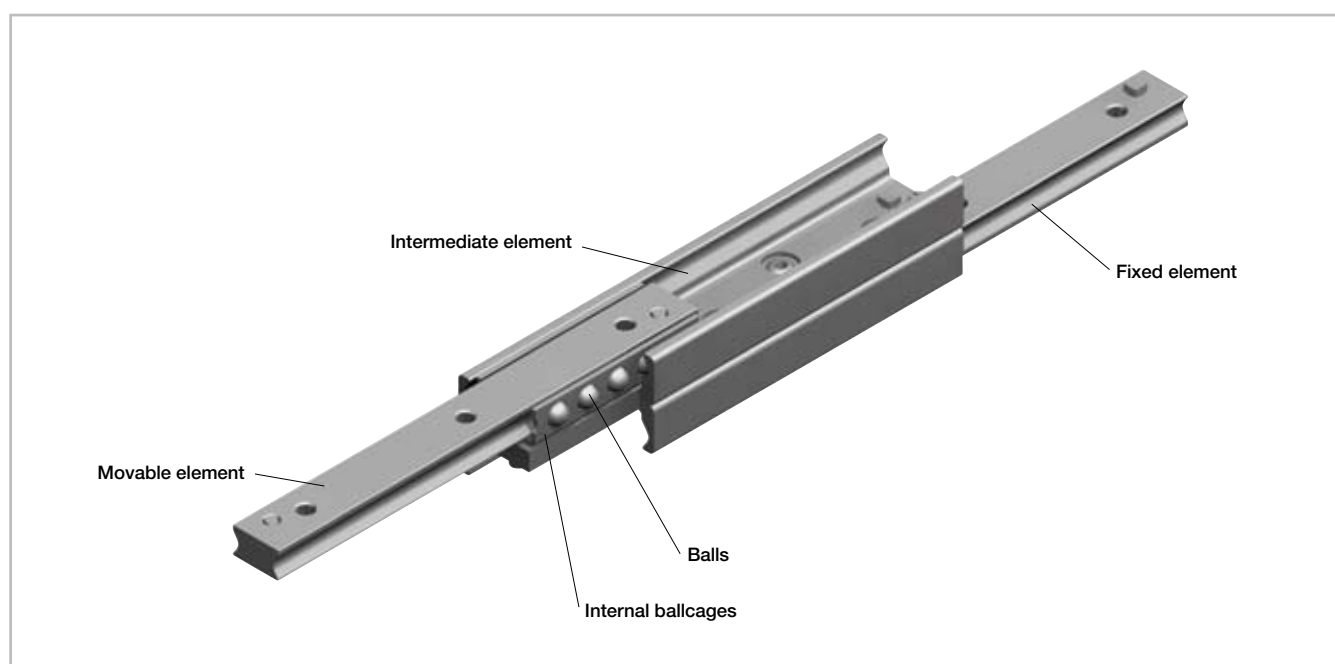

Fig. 9

Performance characteristics:

- Available sizes ASN / DE: 22, 28, 35, 43, 63
- Available sizes DS: 28, 35, 43, 63
- Available sizes DBN: 22, 28, 35, 43
- Available size LTF: 44
- Available size DMS: 63
- Available size DRT: 43
- Induction hardened raceways (except LTF)
- Rails and sliders made of cold-drawn roller bearing steel
- Balls made of hardened roller bearing steel
- Max. operating speed: 0.8 m/s (31.5 in/s)
(depending on application)
- ASN, DE, DBN, LTF temperature range: -30 °C to +170 °C (-22 °F to +338 °F), DS, DRT: -30 °C to +110 °C (-22 °F to +230 °F)
- Electrolytic galvanised as per ISO 2081, increased anticorrosive protection on request (see pg. 36 Anticorrosive protection)

Remarks:

- Horizontal installation is recommended
- Vertical installation on request
- External end stops are recommended
- Double-sided stroke in ASN, DSD, DE, DBN series (DMS on request)
- Custom strokes on request
- All load capacity data are based on one telescopic rail
- All load capacity data are based on continuous operation
- Calculation of the service life is based exclusively on the loaded rows of balls
- For models DSB, DMS and DRT, please observe right or left side use
- DRT 43 must be fixed with Torx® screws (custom design, included in delivery) ASN 63 and DMS 63 can be fixed with Torx® screws as an alternative
- Fixing screws of property class 10.9 must be used for all telescopic rails
- Internal stops are used to stop the unloaded slider and the ball cage. Please use external stops as end stops for a loaded system

Product dimensions

ASN Load capacities

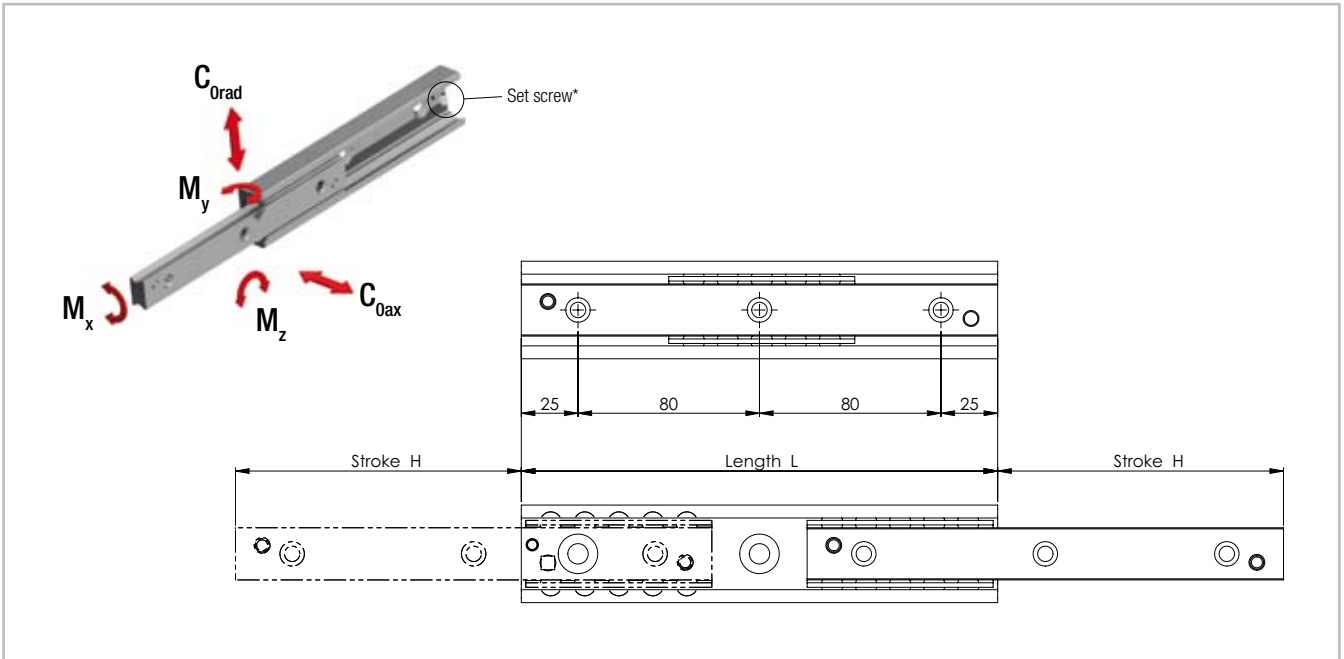

* Remove the set screw to reach all the fixing holes

Fig. 10

Type	Size	Length L [mm]	Stroke H [mm]	Load capacities and moments					No. of holes
				C_{0rad} [N]	C_{0ax} [N]	M_x [Nm]	M_y [Nm]	M_z [Nm]	
ASN	22	130	76	313	219	5,7	10	15	2
		210	111	715	501	10,7	36	51	3
		290	154	994	696	14,9	69	99	4
		370	196	1278	895	19	113	162	5
		450	231	1701	1190	24	180	258	6
		530	274	1979	1385	28,2	248	355	7
		610	316	2262	1584	32,3	327	467	8
		690	351	2689	1882	37,3	436	623	9
		770	394	2967	2077	41,5	539	769	10

Tab. 1

Type	Size	Length L [mm]	Stroke H [mm]	Load capacities and moments					No. of holes
				C _{0rad} [N]	C _{0ax} [N]	M _x [Nm]	M _y [Nm]	M _z [Nm]	
ASN	28	130	74	613	429	15,3	20	28	2
		210	116	1116	781	26,1	57	82	3
		290	148	1934	1354	39,6	132	188	4
		370	190	2445	1711	50,4	213	305	5
		450	232	2955	2069	61,2	314	449	6
		530	274	3466	2426	72	435	621	7
		610	316	3976	2783	82,8	575	821	8
		690	358	4487	3141	93,6	735	1050	9
		770	400	4997	3498	104,4	914	1306	10
		850	433	5828	4080	117,9	1165	1665	11
		930	475	6338	4436	128,7	1389	1984	12
		1010	517	6848	4793	139,5	1631	2330	13
		1090	559	7358	5150	150,3	1894	2705	14
		1170	601	7868	5507	161,1	2175	3108	15
ASN	35	210	127	1065	746	29,4	57	82	3
		290	159	2060	1442	46,9	146	208	4
		370	203	2638	1847	59,9	238	340	5
		450	247	3217	2252	73	354	505	6
		530	279	4282	2997	90,4	543	775	7
		610	323	4858	3401	103,5	711	1015	8
		690	367	5435	3804	116,6	902	1288	9
		770	399	6521	4565	134	1191	1702	10
		850	443	7095	4966	147,1	1435	2050	11
		930	487	7669	5368	160,2	1702	2431	12
		1010	519	8765	6136	177,6	2092	2989	13
		1090	563	9337	6536	190,7	2412	3445	14
		1170	607	9909	6937	203,8	2754	3934	15
		1250	639	11012	7708	221,2	3245	4636	16
		1330	683	11582	8107	234,3	3640	5200	17
		1410	727	12153	8507	247,4	4058	5797	18
1490	759	13260	9282	264,8	4650	6643	19		

Tab. 2

Type	Size	Length L [mm]	Stroke H [mm]	Load capacities and moments					No. of holes
				C _{0rad} [N]	C _{0ax} [N]	M _x [Nm]	M _y [Nm]	M _z [Nm]	
ASN	43	210	123	1595	1117	60.6	84	120	3
		290	158	2872	2010	93.8	201	288	4
		370	208	3377	2364	115.9	308	440	5
		450	243	4690	3283	149.2	509	728	6
		530	278	6039	4227	182.4	762	1088	7
		610	313	7411	5188	215.6	1064	1521	8
		690	363	7863	5504	237.8	1294	1849	9
		770	398	9232	6463	271	1681	2402	10
		850	433	10615	7431	304.2	2119	3027	11
		930	483	11054	7738	326.4	2439	3484	12
		1010	518	12434	8704	359.6	2961	4230	13
		1090	568	12877	9014	381.8	3337	4767	14
		1170	603	14254	9978	415	3943	5633	15
		1250	638	15638	10947	448.2	4599	6571	16
		1330	688	16075	11252	470.4	5065	7236	17
		1410	723	17456	12219	503.6	5806	8295	18
		1490	758	18845	13191	536.8	6598	9425	19
		1570	793	20238	14167	570.1	7440	10628	20
		1650	843	20661	14463	592.2	8029	11470	21
		1730	878	22052	15436	625.5	8956	12794	22
1810	928	22479	15736	647.6	9601	13716	23		
1890	963	23867	16707	680.8	10612	15160	24		
1970	1013	24298	17009	703	11314	16162	25		
ASN	63	610	333	10591	7414	474	1553	2219	8
		690	373	12534	8774	547.5	2072	2960	9
		770	413	14489	10142	621	2666	3808	10
		850	453	16452	11516	694.5	3334	4763	11
		930	493	18421	12895	768	4077	5824	12
		1010	533	20395	14277	841.4	4894	6992	13
		1090	573	22373	15661	914.9	5787	8267	14
		1170	613	24354	17048	988.4	6754	9648	15
		1250	653	26337	18436	1061.9	7795	11136	16
		1330	693	28322	19825	1135.4	8912	12731	17
		1410	733	30309	21216	1208.9	10102	14432	18
		1490	773	32297	22608	1282.4	11368	16240	19
		1570	813	34287	24001	1355.9	12708	18155	20
		1650	853	36277	25394	1429.4	14123	20176	21
		1730	893	38268	26788	1502.8	15613	22304	22
		1810	933	40261	28182	1576.3	17177	24539	23
1890	973	42253	29577	1649.8	18816	26880	24		
1970	1013	44247	30973	1723.3	20530	29328	25		

Tab. 3

ASN Cross-section

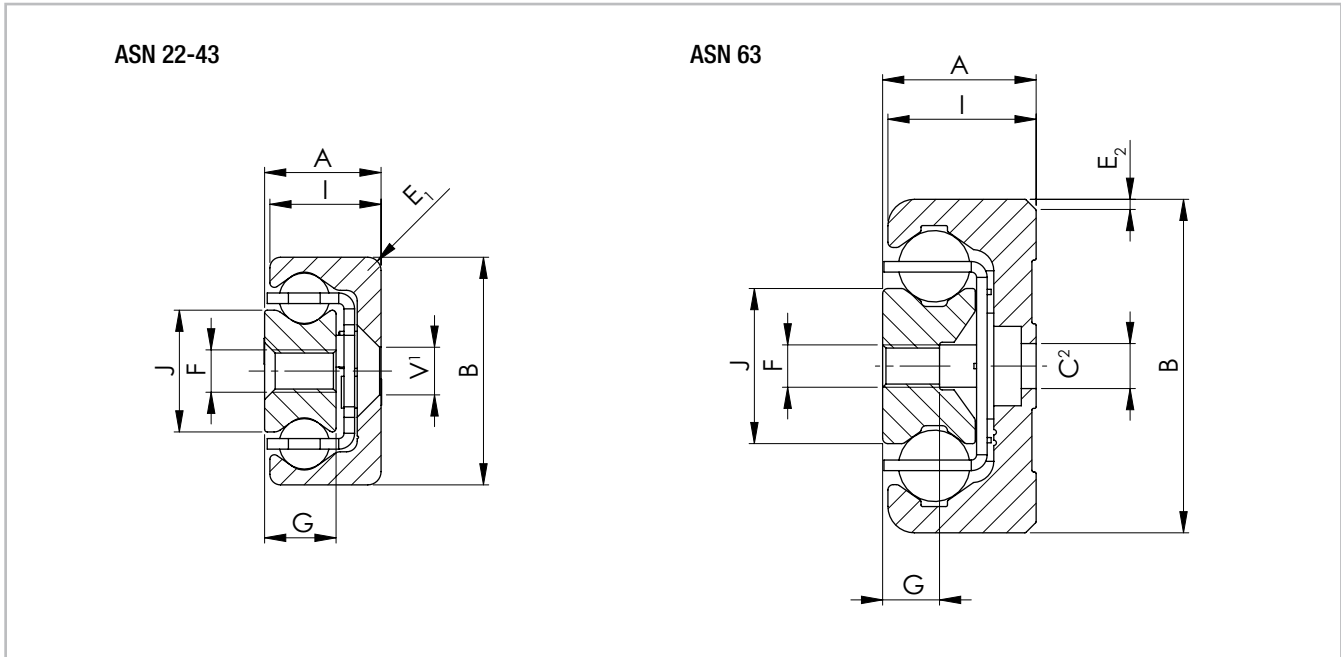

¹ Fixing holes (V) for countersunk head screws according to DIN 7991

² Fixing holes (C) for socket cap screws according to DIN 7984. Alternative fixing with Torx® screws in special design with low head (on request)

Fig. 11

Type	Size	Cross-section										Weight [kg/m]
		A [mm]	B [mm]	I [mm]	J [mm]	G [mm]	E ₁ [mm]	E ₂ [°]	V	C	F	
ASN	22	11	22	10.25	11.3	6.5	3	-	M4	-	M4	1.32
	28	13	28	12.25	15	7.5	1	-	M5	-	M5	2.02
	35	17	35	16	15.8	10	2	-	M6	-	M6	3.05
	43	22	43	21	23	13.5	2.5	-	M8	-	M8	5.25
	63	29	63	28	29.3	10.5	-	2 x 45	-	M8	M8	10.30

Tab. 4

DS Version S Load capacities

Version S with one-sided extension (single stroke)

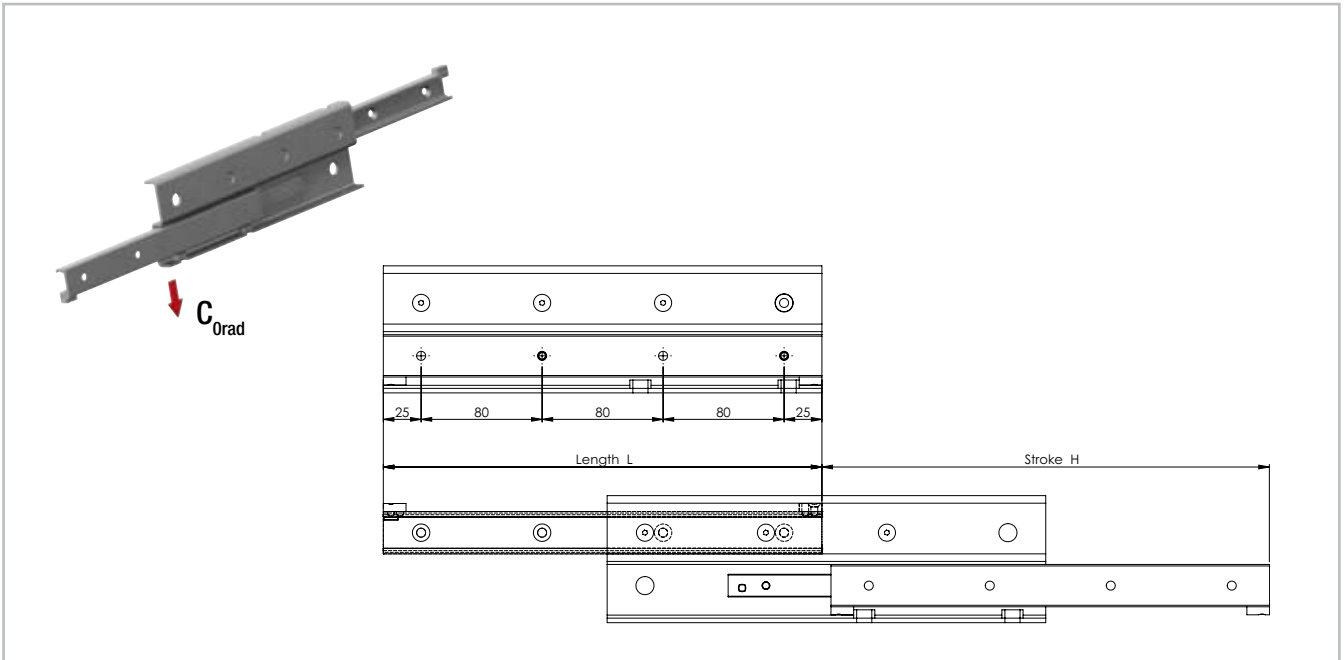

Fig. 12

Type	Size	Length L [mm]	Stroke H [mm]	Load capacity C_{Orad} [N]	Accessible holes / total
DSS	28	290	296	570	3 / 4
		370	380	769	4 / 5
		450	464	969	4 / 6
		530	548	1170	6 / 7
		610	630	1376	6 / 8
		690	714	1577	7 / 9
		770	798	1778	7 / 10
		850	864	2111	9 / 11
		930	950	2240	9 / 12
		1010	1034	2054	10 / 13
		1090	1118	1896	10 / 14
		1170	1202	1761	12 / 15
		1250	1266	1695	12 / 16
		1330	1350	1586	13 / 17
1410	1434	1490	13 / 18		
1490	1518	1405	15 / 19		

Tab. 5

Type	Size	Length L [mm]	Stroke H [mm]	Load capacity C_{Orad} [N]	Accessible holes / total
DSS	35	450	494	1250	5 / 6
		530	558	1685	6 / 7
		610	646	1908	6 / 8
		690	734	2132	7 / 9
		770	798	2579	8 / 10
		850	886	2801	9 / 11
		930	974	3024	9 / 12
		1010	1038	3476	10 / 13
		1090	1126	3508	11 / 14
		1170	1214	3240	12 / 15
		1250	1278	3121	12 / 16
		1330	1366	2907	13 / 17
		1410	1454	2721	14 / 18
		1490	1518	2636	15 / 19
		1570	1606	2482	15 / 20
		1650	1694	2345	16 / 21
		1730	1758	2282	17 / 22

Tab. 6

Type	Size	Length L [mm]	Stroke H [mm]	Load capacity C_{Orad} [N]	Accessi-ble holes / total
DSS	43	530	556	2061	6 / 7
		610	626	2603	6 / 8
		690	726	2775	7 / 9
		770	796	3319	7 / 10
		850	866	3873	9 / 11
		930	966	4036	9 / 12
		1010	1036	4590	10 / 13
		1090	1106	4908	11 / 14
		1170	1206	4610	12 / 15
		1250	1276	4398	12 / 16
		1330	1376	4027	13 / 17
		1410	1446	3864	13 / 18
		1490	1516	3713	15 / 19
		1570	1616	3445	15 / 20
		1650	1686	3325	16 / 21
		1730	1756	3213	16 / 22
		1810	1856	3011	18 / 23
		1890	1926	2919	18 / 24
1970	2026	2750	19 / 25		

Tab. 7

Type	Size	Length L [mm]	Stroke H [mm]	Load capacity C_{Orad} [N]	Accessi-ble holes / total
DSS	63	610	666	3502	6 / 8
		690	746	4252	8 / 9
		770	826	5012	8 / 10
		850	906	5780	9 / 11
		930	986	6552	9 / 12
		1010	1066	7329	11 / 13
		1090	1146	8109	11 / 14
		1170	1226	8892	12 / 15
		1250	1306	9677	12 / 16
		1330	1386	10464	14 / 17
		1410	1466	11252	14 / 18
		1490	1546	12041	15 / 19
		1570	1626	12832	15 / 20
		1650	1706	12364	17 / 21
		1730	1786	11827	17 / 22
		1810	1866	11334	18 / 23
		1890	1946	10881	18 / 24
		1970	2026	10463	20 / 25

Tab. 8

DS version S Cross-section

Version S with one-sided extension (single stroke)

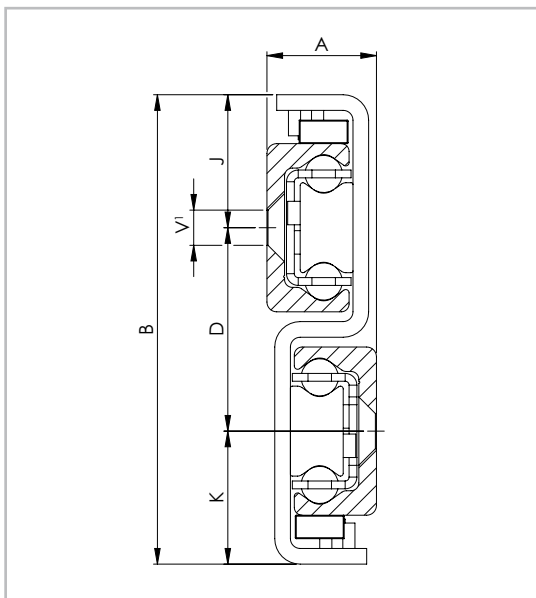

¹ Fixing holes (V) for countersunk head screws according to DIN 7991 Fig. 13

Type	Size	Cross-section						Weight [kg/m]
		A [mm]	B [mm]	K [mm]	D [mm]	J [mm]	V	
DSS	28	17	84	24,5	35	24,5	M5	6,40
	35	22,5	104	30,5	43	30,5	M6	10,10
	43	28	120	34	52	34	M8	14,60
	63	40	208	64	80	64	M10	32,60

Tab. 9

DS Version B

Version B with locking in extracted state (blocking system)

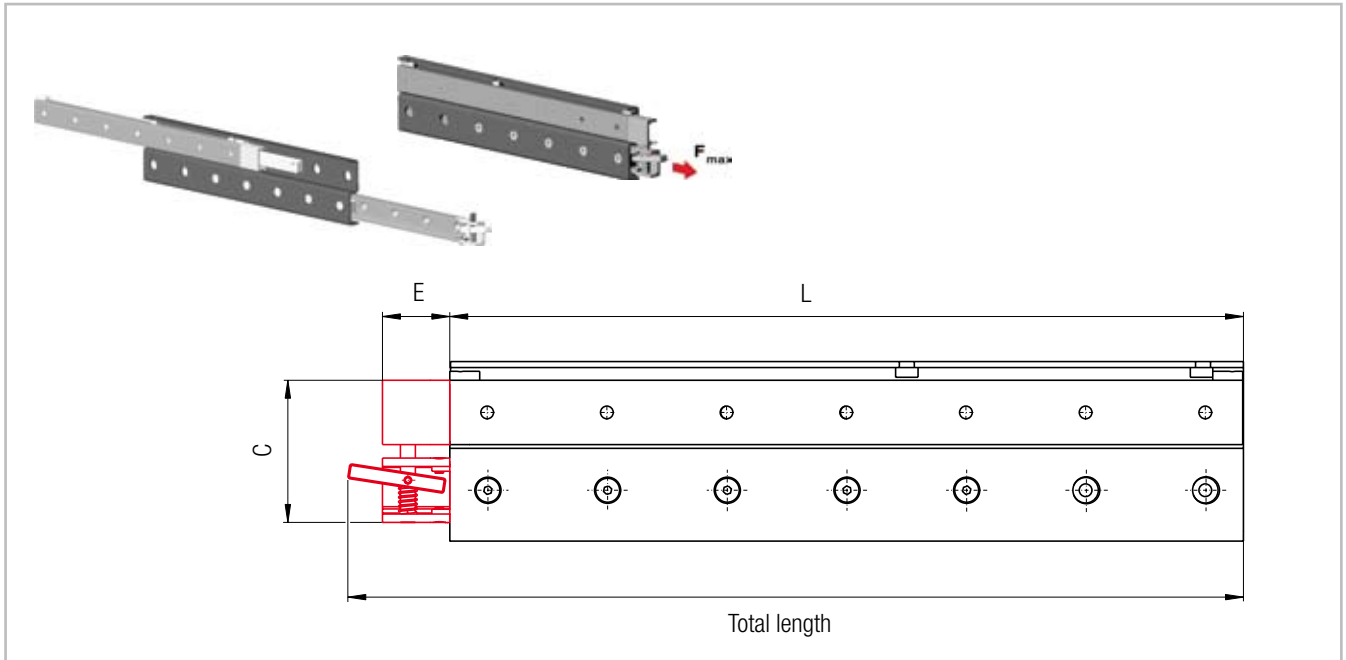

Fig. 14

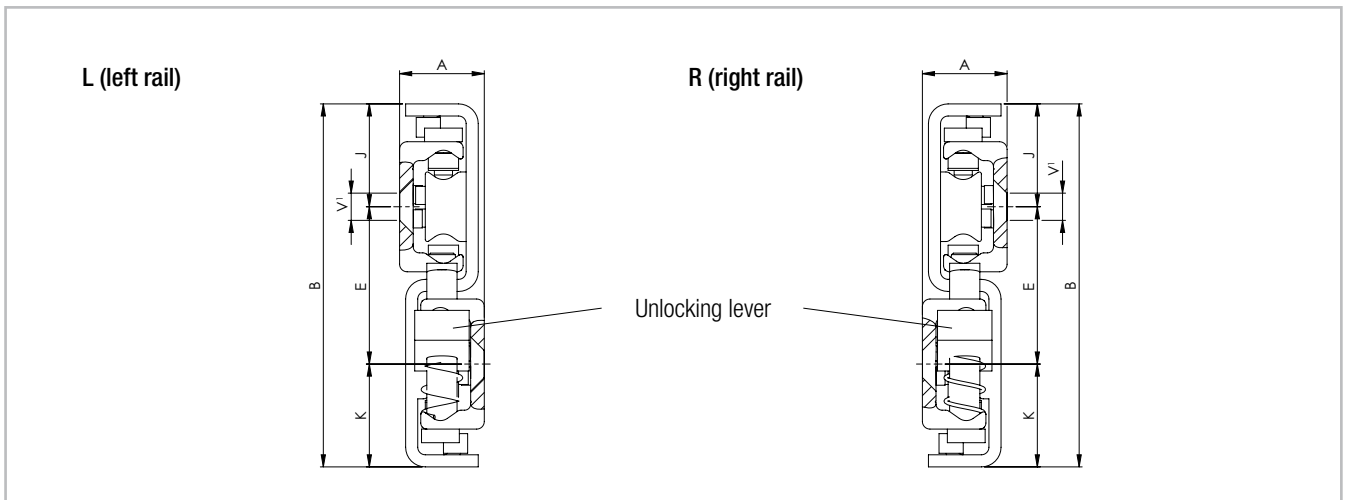

Fig. 15

¹ Fixing holes (V) for countersunk head screws according to DIN 7991

Version DSB is built on the design with one-sided extension (DSS). The same load capacities, cross-sections and available rail lengths apply (see pg. 12ff). Data in Table 10 are based on the special features of the locking mechanism.

Please observe right or left installation for version DSB. The maximum load on the locking in the extension direction is indicated by F_{max} .

Type	Size	L [mm]	Total length [mm]	C [mm]	E [mm]	F_{max} [N]	Weight [kg/m]
DSB	28	from 290 to 1490*	L + 52	63	35	2460	6.51
	43	from 530 to 1970*	L + 69	95	45	5630	14.98

* for available lengths, see pg. 12, tab. 5 and 7 (DSS)

Tab. 10

DS version D Load capacities

Version D with double-sided extension (double stroke)

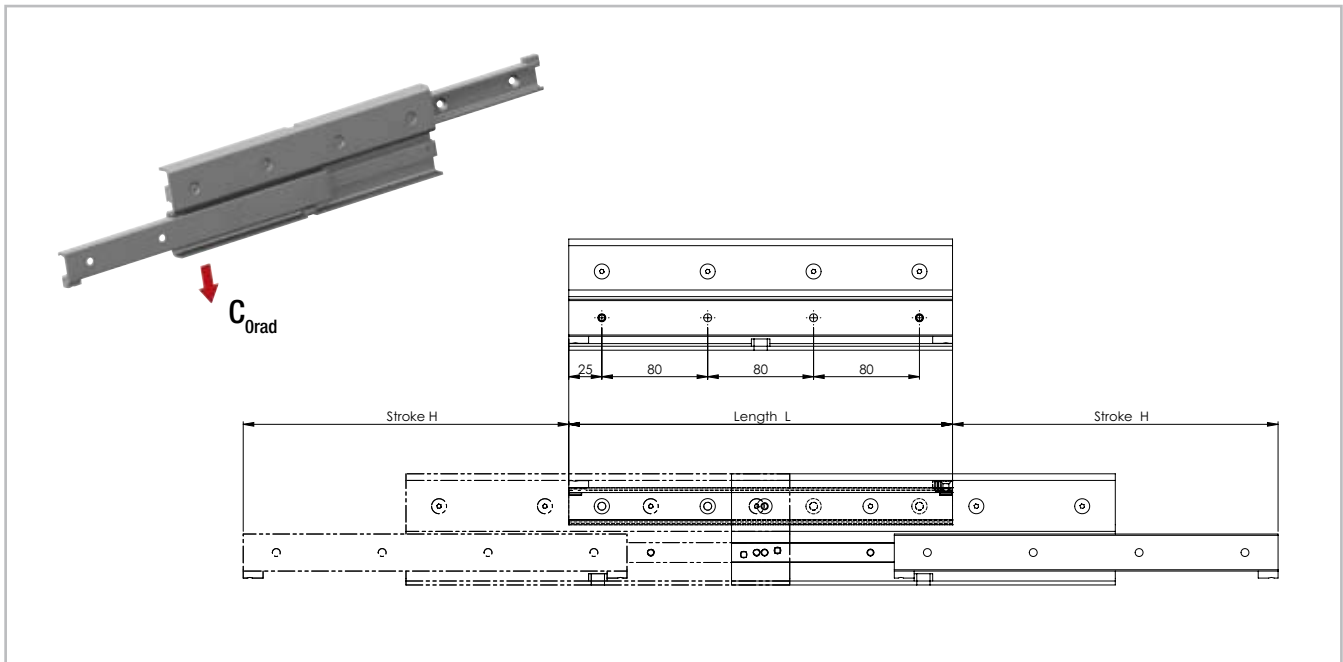

Fig. 16

Type	Size	Length L [mm]	Stroke H [mm]	Load capacity C_{Orad} [N]	No. of holes
DSD	28	290	246	895	4
		370	326	1105	5
		450	406	1317	6
		530	486	1626	7
		610	566	1837	8
		690	646	2050	9
		770	726	2262	10
		850	806	2475	11
		930	886	2581	12
		1010	966	2357	13
		1090	1046	2168	14
		1170	1126	2008	15
		1250	1206	1870	16
		1330	1286	1749	17
		1410	1366	1644	18
		1490	1446	1550	19

Tab. 11

Type	Size	Length L [mm]	Stroke H [mm]	Load capacity C_{Orad} [N]	No. of holes
DSD	43	530	476	3018	7
		610	556	3265	8
		690	636	3781	9
		770	716	4297	10
		850	796	4547	11
		930	876	5063	12
		1010	956	5578	13
		1090	1036	5830	14
		1170	1116	5392	15
		1250	1196	5014	16
		1330	1276	4686	17
		1410	1356	4398	18
		1490	1436	4143	19
		1570	1516	3917	20
		1650	1596	3713	21
		1730	1676	3530	22
		1810	1756	3364	23
		1890	1836	3213	24
		1970	1916	3075	25

Tab. 12

DS version D Cross-section

Version D with double-sided extension (double stroke)

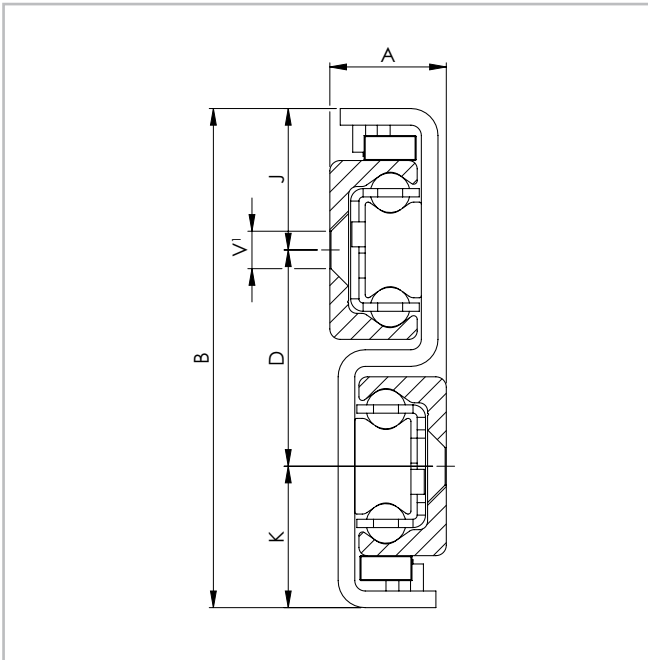

¹ Fixing holes (V) for countersunk head screws according to DIN 7991

Fig. 17

Type	Size	Cross-section						Weight [kg/m]
		A [mm]	B [mm]	K [mm]	D [mm]	J [mm]	V	
DSD	28	17	84	24.5	35	24.5	M5	6.40
	43	28	120	34	52	34	M8	14.60

Tab. 13

DE Load capacities

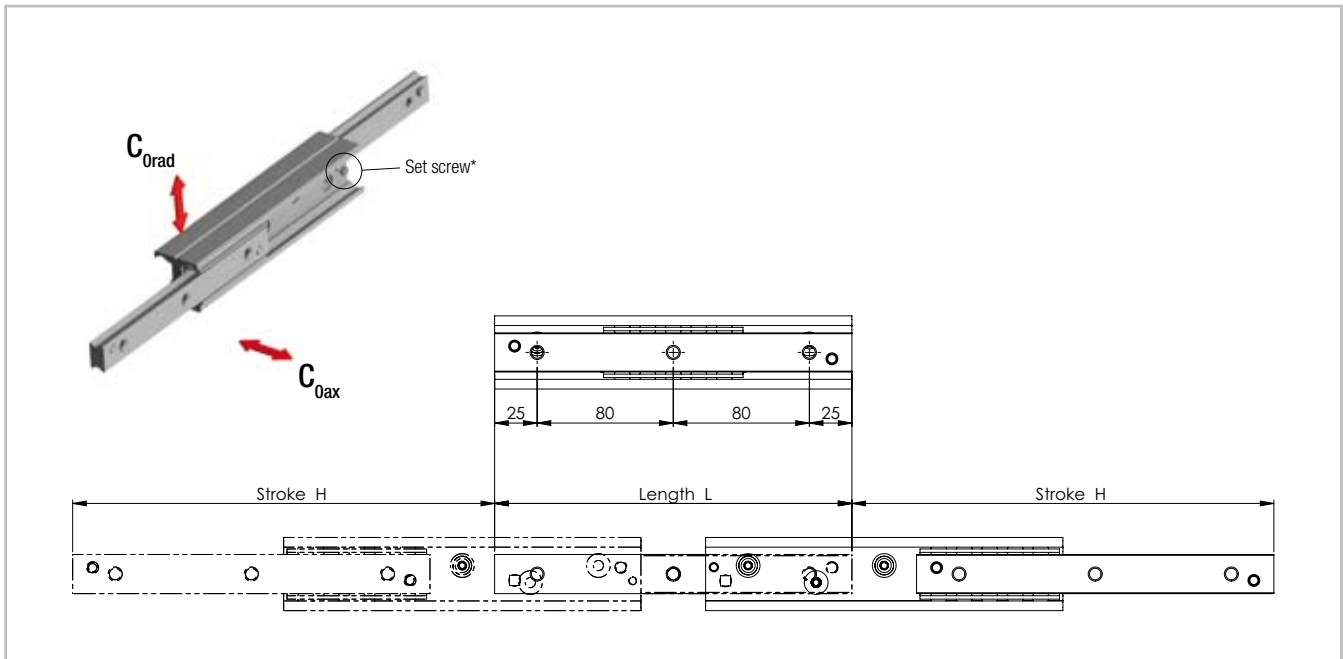

* Remove the set screw to reach all the fixing holes

Fig. 18

There are three versions of fixing holes available for the DE series in sizes 22 to 43:

Version DEF with threaded holes,

Version DEV with counter-sunk holes,

Version DEM, both variants (mixed) (see fig. 19).

Size 63 is only available with threaded holes.

Type	Size	Length L [mm]	Stroke H [mm]	Load capacities		No. of holes
				C_{Orad} [N]	C_{Oax} [N]	
DEF DEV DEM	22	130	152	119	83	2
		210	222	281	196	3
		290	308	390	273	4
		370	392	501	263	5
		450	462	674	230	6
		530	548	571	193	7
		610	632	494	167	8
		690	702	453	153	9
		770	788	401	135	10

Tab. 14

Type	Size	Length L [mm]	Stroke H [mm]	Load capacities		No. of holes
				C_{Orad} [N]	C_{Oax} [N]	
DEF DEV DEM	28	130	148	235	164	2
		210	232	432	302	3
		290	296	767	537	4
		370	380	968	471	5
		450	464	1169	385	6
		530	548	1107	325	7
		610	633	955	280	8
		690	717	842	247	9
		770	801	753	221	10
		850	866	710	208	11
		930	950	646	189	12
		1010	1034	592	174	13
		1090	1118	547	160	14
		1170	1202	508	149	15

Tab. 15

Type	Size	Length L [mm]	Stroke H [mm]	Load capacities		No. of holes
				C _{Orad} [N]	C _{Oax} [N]	
DEF DEV DEM	35	210	254	402	281	3
		290	318	800	560	4
		370	406	1025	718	5
		450	494	1250	793	6
		530	558	1685	728	7
		610	646	1908	626	8
		690	734	1689	548	9
		770	798	1591	516	10
		850	886	1425	463	11
		930	974	1291	419	12
		1010	1038	1233	400	13
		1090	1126	1131	367	14
		1170	1214	1045	339	15
		1250	1278	1006	327	16
		1330	1366	937	304	17
		1410	1454	877	285	18
1490	1518	850	276	19		

Tab. 16

Type	Size	Length L [mm]	Stroke H [mm]	Load capacities		No. of holes
				C _{Orad} [N]	C _{Oax} [N]	
DEF	63	610	666	4090	2863	8
		690	746	4859	3062	9
		770	826	5635	2784	10
		850	906	6415	2553	11
		930	986	7198	2357	12
		1010	1066	6885	2189	13
		1090	1146	6427	2043	14
		1170	1226	6026	1916	15
		1250	1306	5672	1803	16
		1330	1386	5357	1703	17
		1410	1466	5076	1614	18
		1490	1546	4822	1533	19
		1570	1626	4593	1460	20
		1650	1706	4384	1394	21
		1730	1786	4194	1333	22
		1810	1866	4019	1278	23
1890	1946	3859	1227	24		
1970	2026	3710	1180	25		

Tab. 17

Type	Size	Length L [mm]	Stroke H [mm]	Load capacities		No. of holes
				C _{Orad} [N]	C _{Oax} [N]	
DEF DEV DEM	43	210	246	605	424	3
		290	316	1114	780	4
		370	416	1300	910	5
		450	486	1828	1279	6
		530	556	2375	1434	7
		610	626	2934	1300	8
		690	726	3091	1096	9
		770	796	3055	1016	10
		850	866	2847	946	11
		930	966	2506	833	12
		1010	1036	2364	786	13
		1090	1106	2238	744	14
		1170	1206	2022	672	15
		1250	1276	1928	641	16
		1330	1376	1766	587	17
		1410	1446	1694	563	18
		1490	1516	1628	541	19
		1570	1586	1567	521	20
		1650	1686	1458	485	21
		1730	1756	1409	468	22
1810	1856	1320	439	23		
1890	1926	1280	425	24		
1970	2026	1206	401	25		

Tab. 18

DE Cross-section

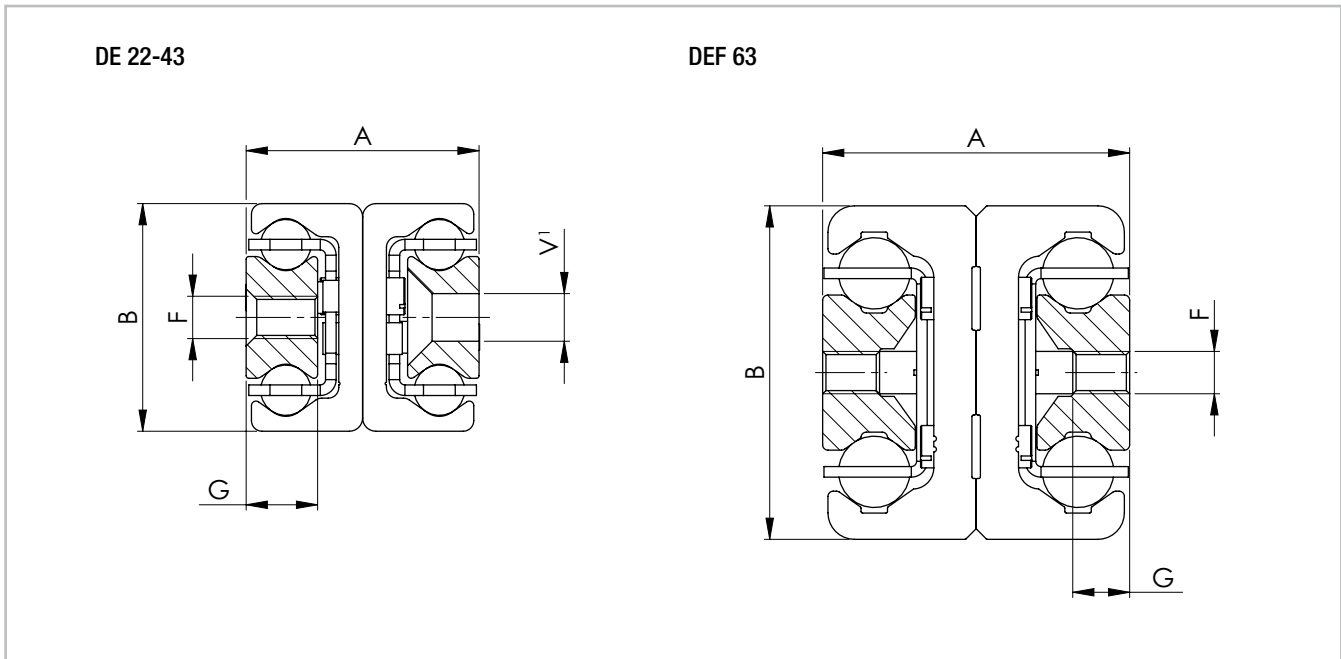

¹ Fixing holes (V) for countersunk head screws according to DIN 7991

Fig. 19

Type	Size	Cross-section					Weight [kg/m]
		A [mm]	B [mm]	G [mm]	F	V	
DEF DEV DEM	22	22	22	6.5	M4	M4	2.64
	28	26	28	7.5	M5	M5	4.04
	35	34	35	10	M6	M6	6.10
	43	44	43	13.5	M8	M8	10.50
	63	58	63	10.5	M8	-	20.60

Tab. 19

Custom Design DE Version D

Version D with driving disc

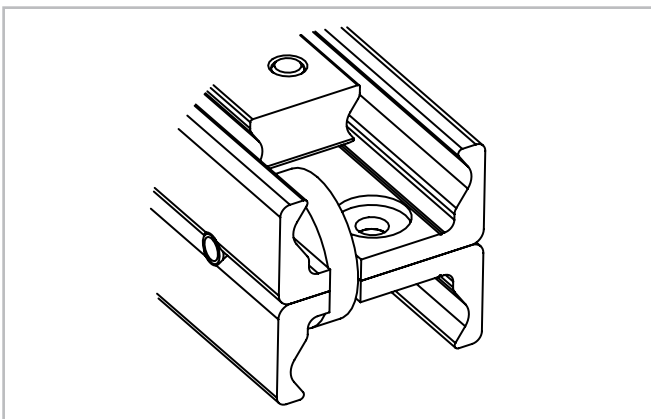
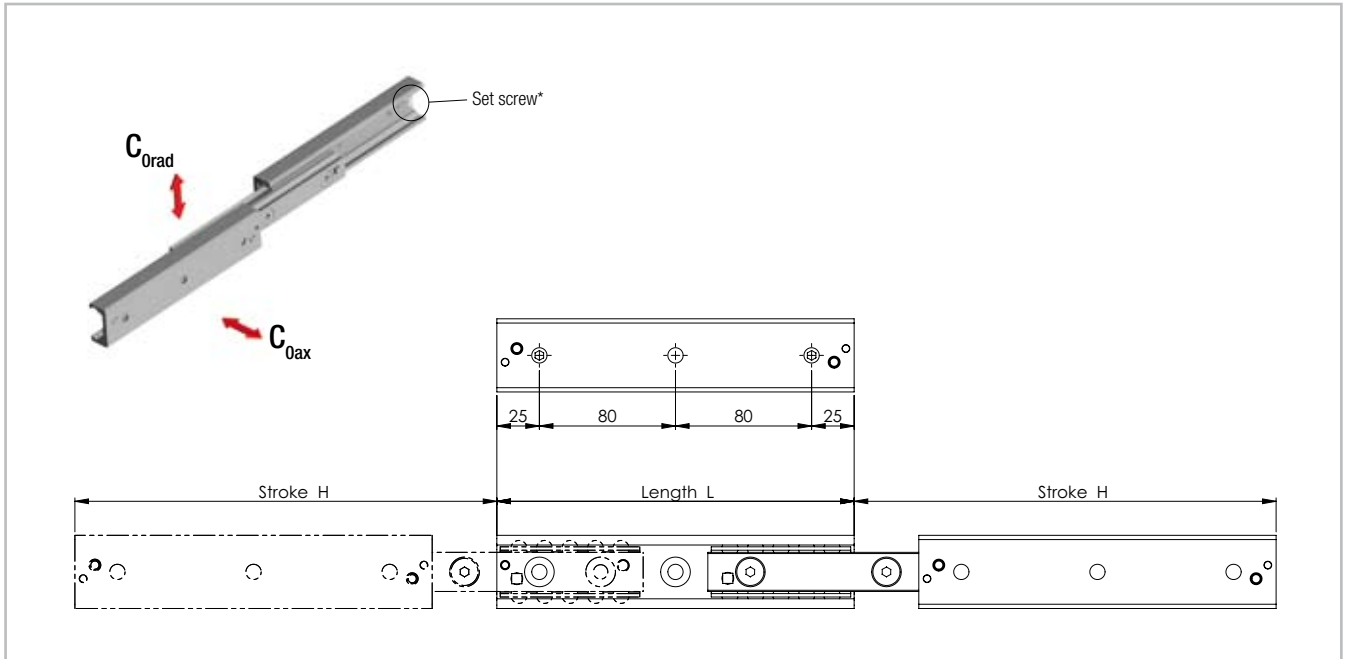

Fig. 20

The eccentrically located driving disc on both ends of the DE...D ensures that the intermediate element is carried along and does not remain standing at an undefined location during double-sided strokes. This custom design is available in sizes 22, 28, 35 and 43 with all three versions of the fixing holes. It is built on the standard design of the DE series, however deviates in the technical data based on the model. For more information please contact Application Technology.

DBN Load capacities



* Remove the set screw to reach all the fixing holes

Fig. 21

Type	Size	Length L [mm]	Stroke H [mm]	Load capacities		No. of holes
				C_{Orad} [N]	C_{Oax} [N]	
DBN	22	130	152	119	83	2
		210	222	281	196	3
		290	308	236	236	4
		370	392	186	186	5
		450	462	162	162	6
		530	548	136	136	7
		610	632	117	117	8
		690	702	108	108	9
		770	788	95	95	10

Tab. 20

Type	Size	Length L [mm]	Stroke H [mm]	Load capacities		No. of holes
				C_{Orad} [N]	C_{Oax} [N]	
DBN	28	130	148	235	164	2
		210	232	432	302	3
		290	296	622	537	4
		370	380	482	482	5
		450	464	393	393	6
		530	548	332	332	7
		610	633	286	286	8
		690	717	252	252	9
		770	801	226	226	10
		850	866	213	213	11
		930	950	194	194	12
		1010	1034	178	178	13
		1090	1118	164	164	14
		1170	1202	152	152	15

Tab. 21

Type	Size	Length L [mm]	Stroke H [mm]	Load capacities		No. of holes
				C _{Orad} [N]	C _{Oax} [N]	
DBN	35	210	254	402	281	3
		290	318	667	560	4
		370	406	522	522	5
		450	494	429	429	6
		530	558	394	394	7
		610	646	338	338	8
		690	734	297	297	9
		770	798	279	279	10
		850	886	250	250	11
		930	974	227	227	12
		1010	1038	217	217	13
		1090	1126	199	199	14
		1170	1214	183	183	15
		1250	1278	177	177	16
		1330	1366	165	165	17
		1410	1454	154	154	18
1490	1518	149	149	19		

Tab. 22

Type	Size	Length L [mm]	Stroke H [mm]	Load capacities		No. of holes
				C _{Orad} [N]	C _{Oax} [N]	
DBN	43	210	246	605	424	3
		290	316	1114	780	4
		370	416	1300	910	5
		450	486	1331	1279	6
		530	556	1193	1193	7
		610	626	1082	1082	8
		690	726	912	912	9
		770	796	845	845	10
		850	866	788	788	11
		930	966	693	693	12
		1010	1036	654	654	13
		1090	1106	619	619	14
		1170	1206	559	559	15
		1250	1276	533	533	16
		1330	1376	488	488	17
		1410	1446	469	469	18
		1490	1516	450	450	19
		1570	1586	434	434	20
		1650	1686	403	403	21
		1730	1756	390	390	22
1810	1856	365	365	23		
1890	1926	354	354	24		
1970	2026	334	334	25		

Tab. 23

DBN Cross-section

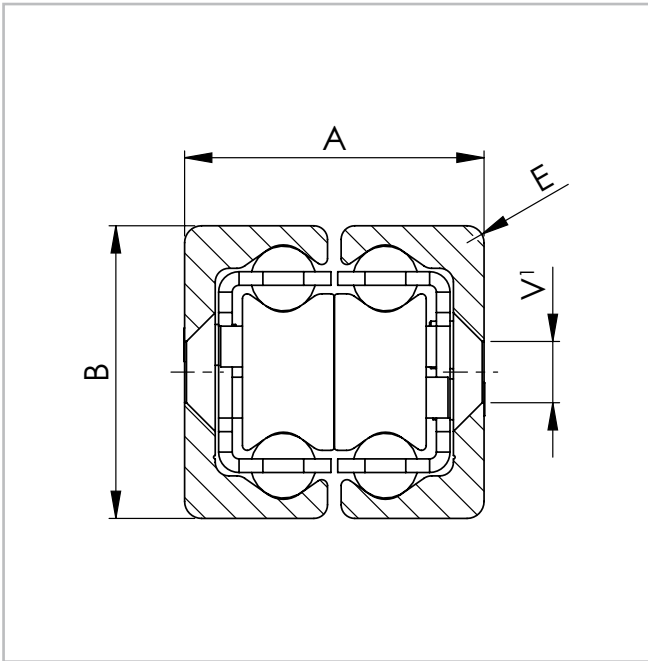

¹ Fixing holes (V) for countersunk head screws according to DIN 7991

Fig. 22

Type	Size	Cross-section				Weight [kg/m]
		A [mm]	B [mm]	E [mm]	V	
DBN	22	22	22	3	M4	2.64
	28	26	28	1	M5	4.04
	35	34	35	2	M6	6.10
	43	44	43	2.5	M8	10.50

Tab. 24

LTF Load capacities

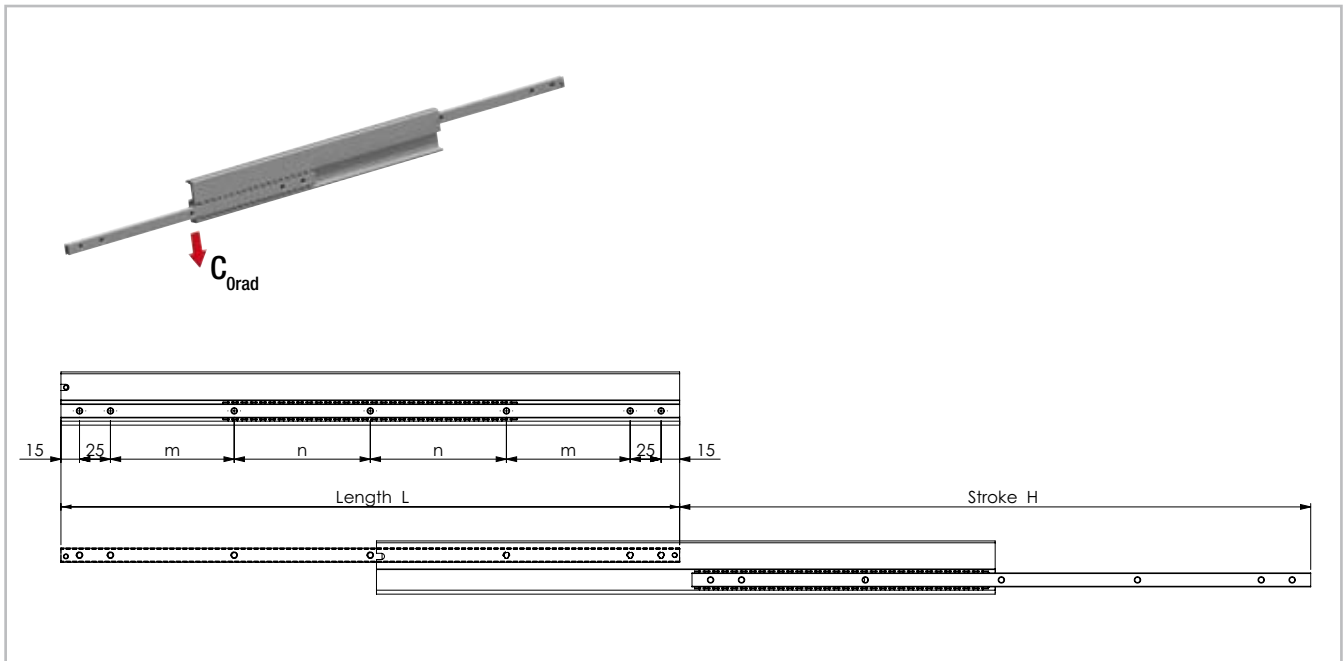

Fig. 23

Type	Size	Length L [mm]	Stroke H [mm]	Load capacity C_{Orad} [N]	Fixed and movable rail		
					m [mm]	n [mm]	No. of holes
LTF	44	200	210	114	60	0	5
		225	235	130	72.5		
		250	260	144	85		
		275	285	162	97.5		
		300	310	180	110		
		325	335	196	122.5		
		350	360	210	135		
		375	385	226	147.5		
		400	410	246	160		
		425	435	262	172.5		
	450	460	276	185			
	500	510	312	100	110	7	
	550	560	342		135		
	600	610	384		160		
	650	660	408		185		
	700	710	444	150	160		
	750	760	474		185		
	800	810	510		210		
	850	860	540		235		
	900	910	576		260		
950	960	612	285				
1000	1010	648	310				

Tab. 25

LTF Cross-section

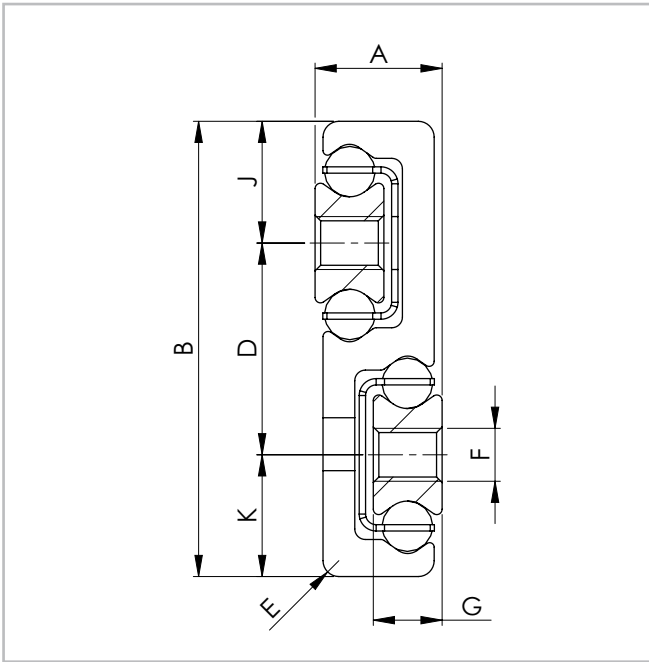

Fig. 24

Type	Size	Cross-section								Weight [kg/m]
		A [mm]	B [mm]	K [mm]	D [mm]	J [mm]	E [mm]	G [mm]	F	
LTF	44	12	43	11.5	20	11.5	1.5	6.5	M5	2.70

Tab. 26

DMS Load capacities

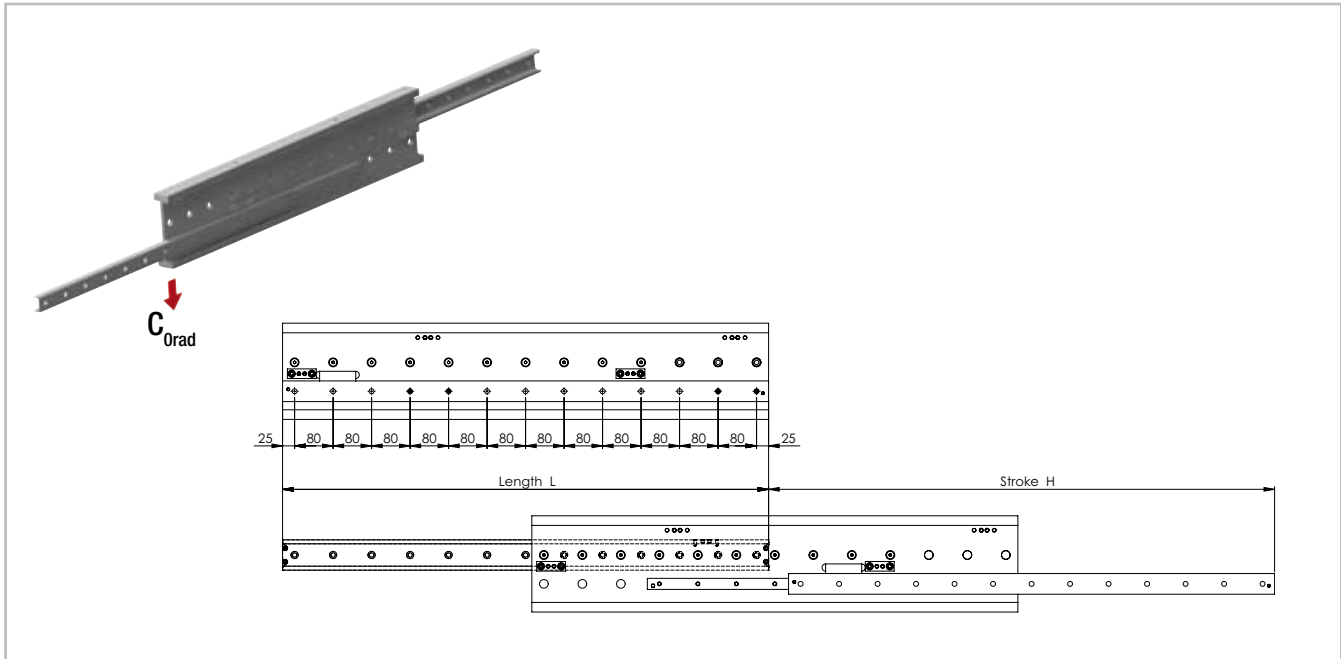
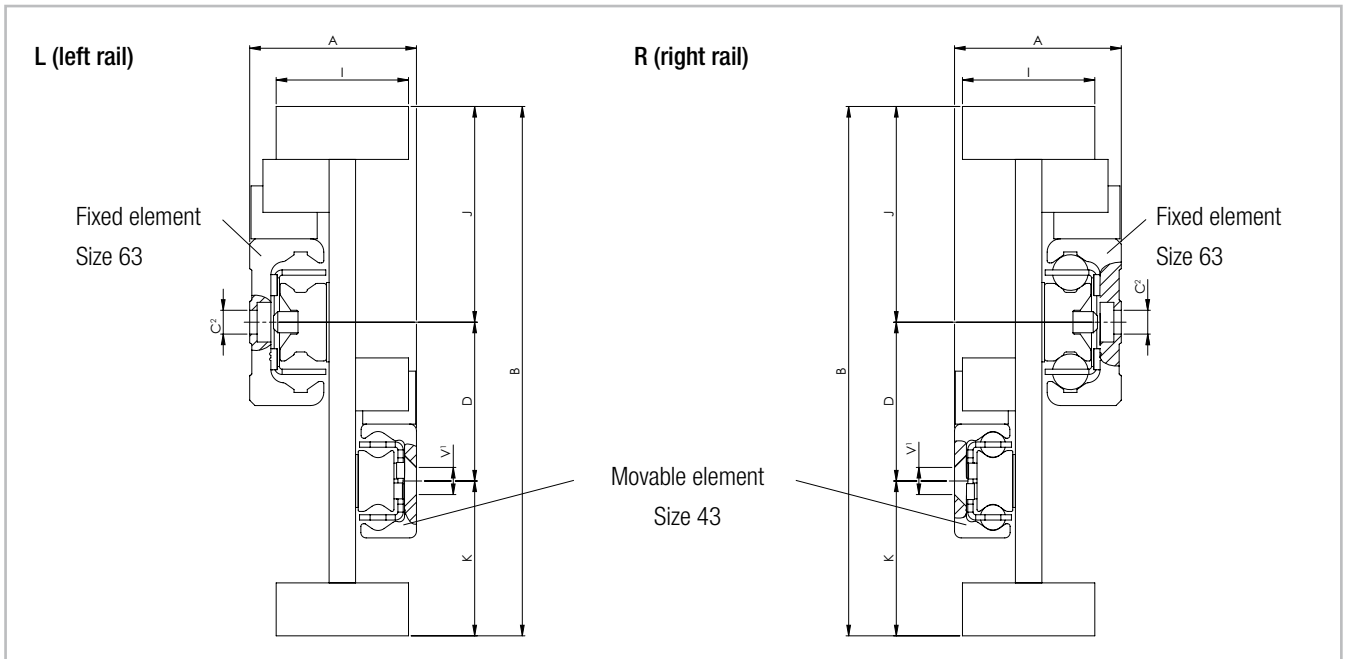

Fig. 25

Type	Size	Length L [mm]	Stroke H [mm]	Load capacity C_{Orad} [N]	Fixed element Accessible holes / total	Movable element Accessible holes / total
DMS	63	1010	1051	8052	10 / 13	10 / 13
		1090	1141	8748	10 / 14	11 / 14
		1170	1216	9584	11 / 15	11 / 15
		1250	1291	10424	12 / 16	13 / 16
		1330	1381	11119	13 / 17	13 / 17
		1410	1456	11960	13 / 18	14 / 18
		1490	1531	12804	14 / 19	14 / 19
		1570	1621	13498	14 / 20	15 / 20
		1650	1696	14343	16 / 21	16 / 21
		1730	1771	15190	16 / 22	17 / 22
		1810	1861	15883	17 / 23	17 / 23
		1890	1936	16730	18 / 24	19 / 24
		1970	2026	17423	19 / 25	19 / 25
		2050	2101	18271	19 / 26	20 / 26
		2130	2176	19120	20 / 27	20 / 27
2210	2266	19812	21 / 28	22 / 28		

Tab. 27

DMS Cross-section



¹ Fixing holes (V) for countersunk head screws according to DIN 7991

² Fixing holes (C) for socket cap screws according to DIN 7984. Alternative fixing with Torx® screws in special design with low head (on request)

Fig. 26

Type	Size	Cross-section								Weight [kg/m]
		A [mm]	B [mm]	I [mm]	K [mm]	D [mm]	J [mm]	C	V	
DMS	63	63	200	50	58.5	60	81.5	M8	M8	43

Tab. 28

DRT Load capacities

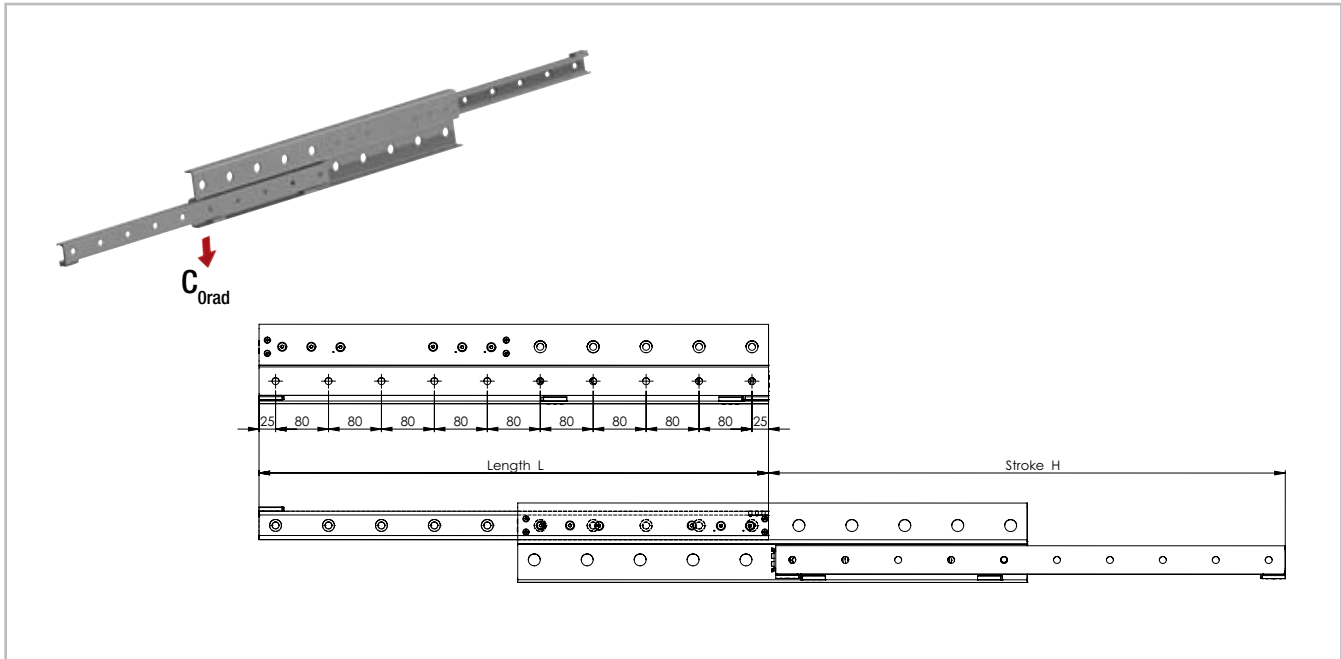
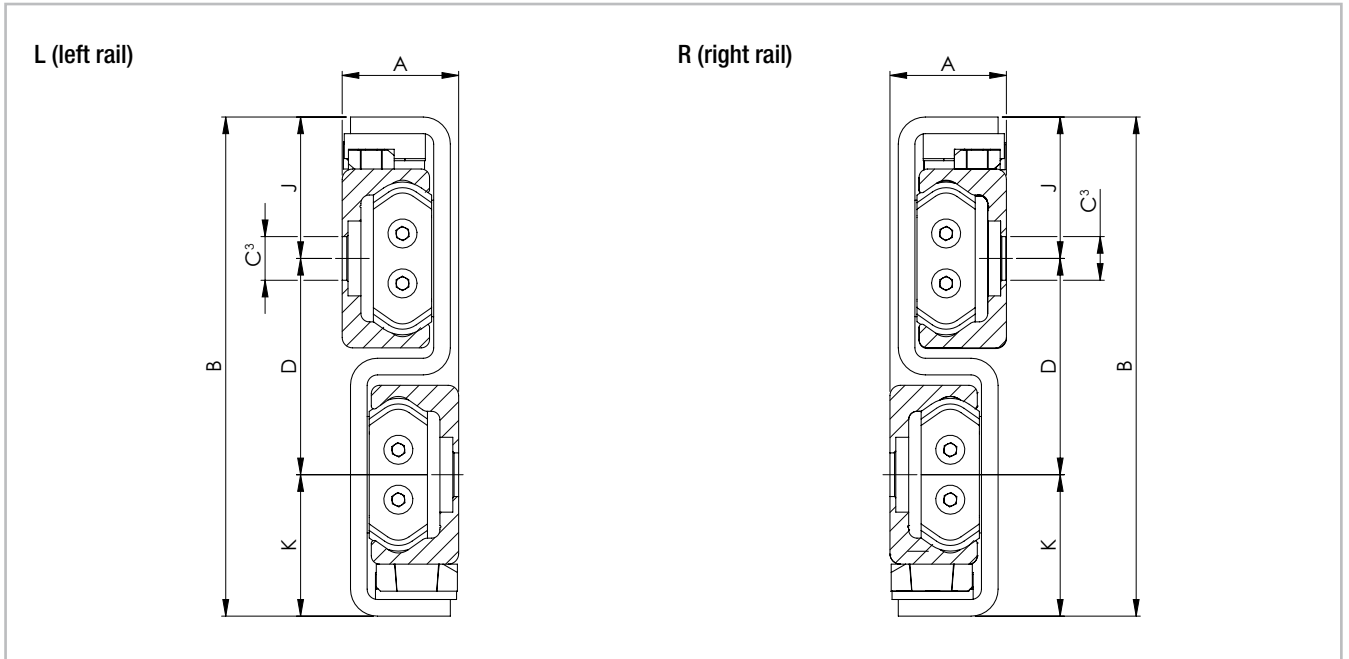

Fig. 27

Type	Size	Length L [mm]	Stroke H [mm]	Load capacity C_{Orad} [N]	Accessible holes / total
DRT	43	770	780	2385	10 / 10
		850	860	2460	10 / 11
		930	940	2520	12 / 12
		1010	1020	2575	12 / 13
		1090	1100	2620	14 / 14
		1170	1180	2660	14 / 15
		1250	1260	2690	16 / 16
		1330	1340	2720	16 / 17
		1410	1420	2745	18 / 18
		1490	1500	2770	18 / 19
		1570	1580	2790	20 / 20
		1650	1660	2805	20 / 21
		1730	1740	2825	22 / 22
		1810	1820	2840	22 / 23
		1890	1900	2850	24 / 24
1970	1980	2860	24 / 25		

Tab. 29

DRT Cross-section



³ Fixing holes for Torx® screws in custom design with load head (included in scope of supply)

Fig. 28

Type	Size	Cross-section						Weight [kg/m]
		A [mm]	B [mm]	K [mm]	D [mm]	J [mm]	C	
DRT	43	29	120	34	52	34	M8	11.20

Tab. 30

Technical instructions

Selection of the telescopic rail

Selecting the suitable telescopic rail should be done based on the load and the maximum permissible deflexion in the extended state. The load capacity of a telescopic rail depends on two factors: the loading capacity of the ballcage and the rigidity of the intermediate element. For mainly short strokes the load capacity is determined by the load-bearing capacity of the ballcage; for average and long strokes it is determined by the rigidity of the intermediate element. Therefore series, which otherwise contain comparable components, are also suited for differing load capacities.

Load capacities

The values in the load capacity tables of the corresponding series (see Sect. 3, Product Dimensions, pg. 8ff) give the maximum permissible loading of a telescopic rail in the centre of the movable rail in the completely extended state.

All load capacity data is based on a telescopic rail.

Typically, a pair of rails is used and the loading acts in the centre on both rails (see fig. 30, P_1).

In this case, the load capacity of a rail pair is:

$$P_1 = 2 \cdot C_{\text{Orad}}$$

Fig. 29

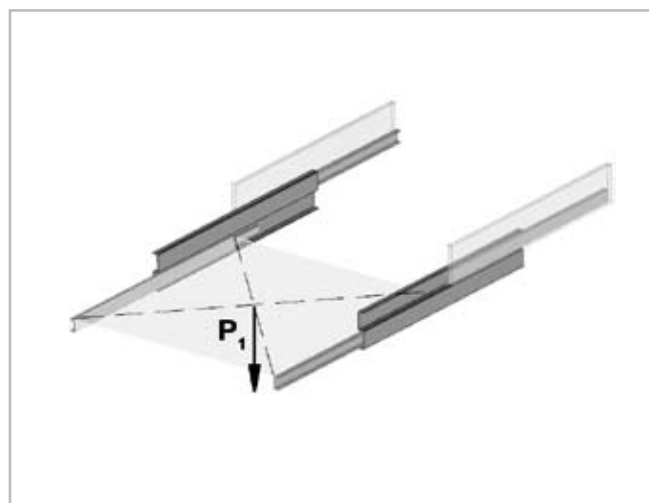

Fig. 30

Deflexion

If the load P acts vertically on the rail (see fig. 33), the expected elastic deflexion of the individual telescopic rail in the extended state can be determined as follows:

$$f = \frac{q}{t} \cdot P \text{ (mm)}$$

Fig. 31

Whereby:

f is the expected elastic deflexion in mm

q is a stroke coefficient (see fig. 34)

t is a factor depending on the model of the telescopic rail (see fig. 32)

P is the actual load acting on the centre of a rail, in N

Also refer to page 31 for checking the static load

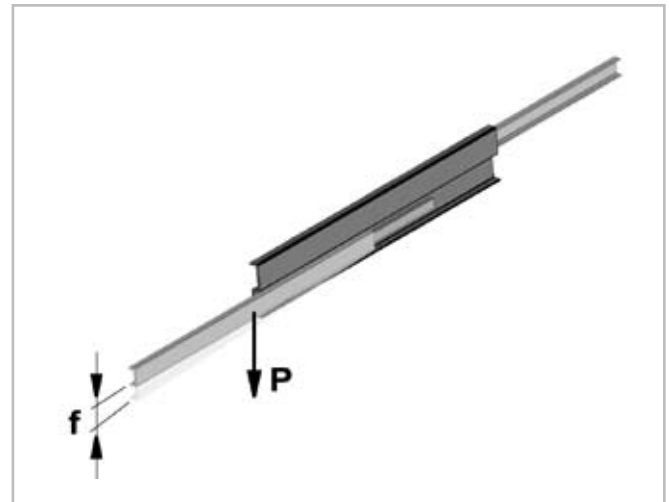

Fig. 33

DS28	$t = 180$	DBN22	$t = 3$
DS35	$t = 470$	DBN28	$t = 8$
DS43	$t = 800$	DBN35	$t = 13$
DS63	$t = 4000$	DBN43	$t = 56$
DE22	$t = 8$	LTF44	$t = 25$
DE28	$t = 17$	DMS63	$t = 3500$
DE35	$t = 54$	DRT43	$t = 800$
DE43	$t = 120$		
DE63	$t = 540$		

Fig. 32

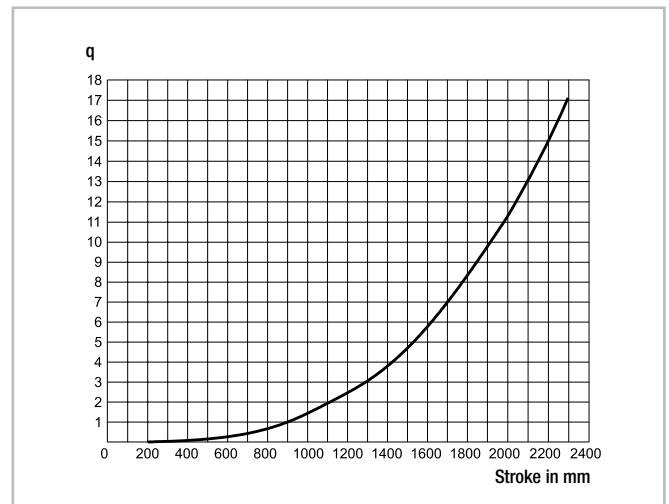

Fig. 34

Note: The above formula (see fig. 31) applies to a single rail. When using a rail pair, the load of the single rail is $P = P_r/2$ (see pg. 29, fig. 30). This estimated value assumes an absolutely rigid adjacent construction. If this rigidity is not present, the actual deflexion will deviate from the calculation.

Important:

With the partial extensions of the ASN series, the deflexion is almost completely determined by the rigidity, i.e. by the moment of inertia of the adjacent construction.

Static load

The telescopic extension of the various series accept different forces and moments (see Sect. 3, Product dimensions, pg. 8ff).

During the static tests the radial load capacity, C_{Orad} , the axial load capacity, C_{Oax} , and moments M_x , M_y and M_z indicate the maximum permissible values of the loads; higher loads negatively effect the running properties

and the mechanical strength. A safety factor, S_0 , is used to check the static load, which takes into account the basic parameters of the application and is defined in more detail in the following table:

Safety factor S_0

Neither shocks nor vibrations, smooth and low-frequency reverse, high assembly accuracy, no elastic deformations	1 - 1.5
Normal installation conditions	1.5 - 2
Shocks and vibrations, high-frequency reverse, significant elastic deformation	2 - 3.5

Tab. 31

The ratio of the actual load to maximum permissible load may be as large as the reciprocal of the accepted safety factor, S_0 , at the most.

$$\frac{P_{Orad}}{C_{Orad}} \leq \frac{1}{S_0} \quad \frac{P_{Oax}}{C_{Oax}} \leq \frac{1}{S_0} \quad \frac{M_1}{M_x} \leq \frac{1}{S_0} \quad \frac{M_2}{M_y} \leq \frac{1}{S_0} \quad \frac{M_3}{M_z} \leq \frac{1}{S_0}$$

Fig. 35

The above formulas are valid for a single load case. If two or more of the described forces act simultaneously, the following check must be made:

$$\frac{P_{Orad}}{C_{Orad}} + \frac{P_{Oax}}{C_{Oax}} + \frac{M_1}{M_x} + \frac{M_2}{M_y} + \frac{M_3}{M_z} \leq \frac{1}{S_0}$$

- P_{Orad} = effective radial load
- C_{Orad} = permissible radial load
- P_{Oax} = effective axial load
- C_{Oax} = permissible axial load
- M_1 = effective moment in the x-direction
- M_x = permissible moment in the x-direction
- M_2 = effective moment in the y-direction
- M_y = permissible moment in the y-direction
- M_3 = effective moment in the z-direction
- M_z = permissible moment in the z-direction

Fig. 36

Service life

The service life is defined as the time span between commissioning and the first fatigue or wear indications on the raceways. The service life of a telescopic rail is dependent on several factors, such as the effective load, the installation precision, occurring shocks and vibrations, the operating temperature, the ambient conditions and the lubrication. Calculation of the service life is based exclusively on the loaded rows of balls.

In practice, the decommissioning of the bearing, due to its destruction or extreme wear of a component, represents the end of service life.

This is taken into account by an application coefficient (f_i in the formula below), so the service life consists of:

$$L_{km} = 100 \cdot \left(\frac{\delta}{W} \cdot \frac{1}{f_i} \right)^3$$

L_{km} = calculated service life in km

δ = load capacity factor in N

W = equivalent load in N

f_i = application coefficient

Fig. 37

Application coefficient f_i

	ASN, DS, DE, DBN, DRT	LTF
Neither shocks nor vibrations, smooth and low-frequency direction change, clean environment	1.3 - 1.8	2.3 - 2.8
Light vibrations and average direction change	1.8 - 2.3	2.8 - 3.3
Shocks and vibrations, high-frequency direction change, very dirty environment	2.3 - 3.5	3.3 - 4.5

Tab. 32

If the external load, P , is the same as the dynamic load capacity, C_{Orad} (which of course must never be exceeded), the service life at ideal operating conditions ($f_i = 1$) amounts to 100 km.

Naturally, for a single load P , the following applies: $W = P$. If several external loads occur simultaneously, the equivalent load is calculated as follows:

$$W = P_{rad} + \left(\frac{P_{ax}}{C_{Oax}} + \frac{M_1}{M_x} + \frac{M_2}{M_y} + \frac{M_3}{M_z} \right) \cdot C_{Orad}$$

Fig. 38

Load capacity factor δ

Length [mm]	ASN				
	22	28	35	43	63
	δ [N]				
130	415	872			
210	932	1577	1533	2288	
290	1295	2692	2906	4055	
370	1665	3405	3721	4794	
450	2205	4119	4537	6602	
530	2567	4832	5990	8451	
610	2936	5557	6803	10325	15003
690	3480	6271	7617	11005	17708
770	3842	6984	9093	12877	20427
850		8111	9903	14762	23155
930		8811	10714	15429	25889
1010		9524	12201	17310	28629
1090		10237	13009	17981	31374
1170		10950	13818	19860	34121
1250			15311	21747	36871
1330			16118	22411	39623
1410			16925	24295	42377
1490			18423	26186	45133
1570				28083	47890
1650				28733	50648
1730				30626	53407
1810				31281	56166
1890				33172	58927
1970				33829	61688

Tab. 33

Length [mm]	DS...			
	28	35	43	63
	δ [N]			
290	863			
370	1164			
450	1466	1892		
530	1768	2540	3120	
610	2078	2878	3929	5328
690	2381	3217	4197	6459
770	2684	3881	5010	7604
850	3180	4218	5836	8759
930	3474	4555	6090	9921
1010	3778	5226	6916	11089
1090	4081	5561	7750	12261
1170	4384	5897	7646	13437
1250	4896	6573	8829	14616
1330	5193	6907	9077	15798
1410	5496	7242	9909	16981
1490	5806	7920	10746	18166
1570		8253	10988	19353
1650		8588	11825	20540
1730		9268	12665	21729
1810			12904	22919
1890			13743	24109
1970			13983	25301

Tab. 34

Length [mm]	DRT	DMS
	43	63
	δ [N]	
770	5160	
850	5306	
930	5424	
1010	5522	12154
1090	5605	14987
1170	5675	14457
1250	5736	16486
1330	5789	16763
1410	5836	19842
1490	5878	19285
1570	5915	22158
1650	5948	21598
1730	5978	24707
1810	6005	23911
1890	6030	25963
1970	6053	26225
2050		29341
2130		28763
2210		30595

Tab. 35

Length [mm]	DE... / DBN				DE
	22	28	35	43	63
	δ [N]				
130	165	357			
210	386	655	614	923	
290	537	1153	1211	1687	
370	690	1456	1552	1974	
450	925	1759	1892	2764	
530	1075	2063	2540	3580	
610	1229	2372	2878	4414	6203
690	1467	2675	3217	4661	7361
770	1616	2979	3881	5493	8527
850		3487	4218	6335	9699
930		3783	4555	6572	10875
1010		4086	5226	7411	12055
1090		4388	5561	8257	13238
1170		4691	5897	8489	14423
1250			6573	9332	15610
1330			6907	9568	16798
1410			7242	10409	17987
1490			7920	11255	19178
1570				12105	20369
1650				12330	21561
1730				13178	22754
1810				13406	23948
1890				14252	25142
1970				14483	26336

Tab. 36

Length [mm]	LTF
	44
	δ [N]
200	163
225	191
250	215
275	243
300	267
325	295
350	319
375	347
400	372
425	400
450	424
500	476
550	529
600	581
650	633
700	686
750	738
800	791
850	843
900	896
950	948
1000	1000

Tab. 37

Speed

The maximum operating speed is determined by the mass of the intermediate element, which moves with the movable rail. This reduces the maximum permissible operating speed with increasing length (see fig. 39).

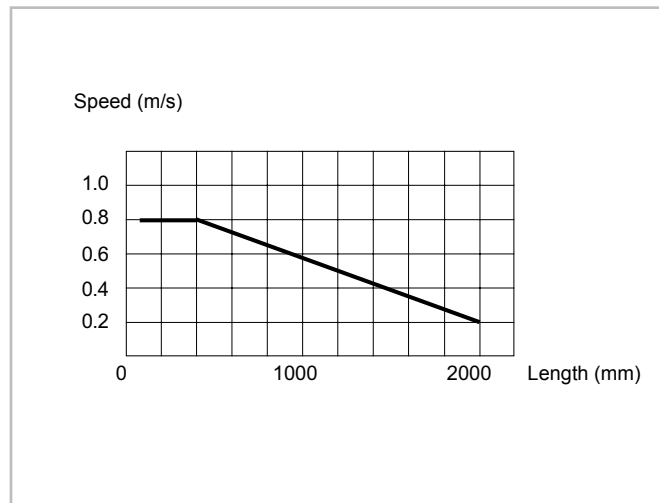

Fig. 39

Extension and extraction force

The required actuation forces of a telescopic rail depend on the acting load and the deflexion in the extended state. The force required for opening is principally determined by the coefficient of friction of the linear bearing. With correct assembly and lubrication, this is 0.01. During the extension, the force is reduced with the elastic deflexion of the loaded

telescopic rail. A higher force is required to close a telescopic extension, since, based on the elastic deflexion, even if it is minimal, the movable rail must move against an inclined plane.

Double-sided stroke

For all designs allowing double-sided stroke, it must be observed that the position of the intermediate element is defined only in the extended state. In the extracted state, the intermediate element can protrude by half of its length on each side. Exception is the ASN series, which comes out as a partial extension without an intermediate element and the custom design of series DE with driving disc.

The double-sided stroke in series ASN, DE und DBN is achieved by removing the set screw. For series DS version D, the double-sided stroke is implemented by design adaptation. Double-sided stroke for series DMS on request. Series DS version B, DRT and LTF are not available with double-sided stroke.

Temperature

- Series ASN, DE, DBN and LTF can be used up to an ambient temperature of +170 °C (+338 °F). A lithium lubricant for high operating temperatures is recommended for temperatures above +130 °C (+266 °F).
- Series DS and DRT have a useable range of -30 °C to +110 °C (-22 °F to +230 °F) because of the rubber stop.

Anticorrosive protection

- All of the Telescopic Rail product series have a standard anticorrosive protection by electrolytic galvanisation according to ISO 2081. If increased anticorrosive protection is required, the rails are available chemically nickel plated and with corrosion resistant steel balls.
- Numerous application-specific surface treatments are available upon request, e.g., as a nickel-plated design with FDA approval for use in the food industry.
For more information please contact Application Technology.

Lubrication

- Recommended lubrication intervals are heavily dependent upon the ambient conditions, speed and temperature. Under normal conditions, lubrication is recommended after 100 km operational performance or after an operating period of six months. In critical application cases the interval should be shorter. Please clean the raceways carefully before lubrication. Raceways and spaces of the ball cage are lubricated with a lithium lubricant of average consistency (roller bearing lubricant).
- Different lubricants for special applications are available upon request.
Example: Lubricant with FDA approval for use in the food industry.
For more information please contact Application Technology.

Fixing screws

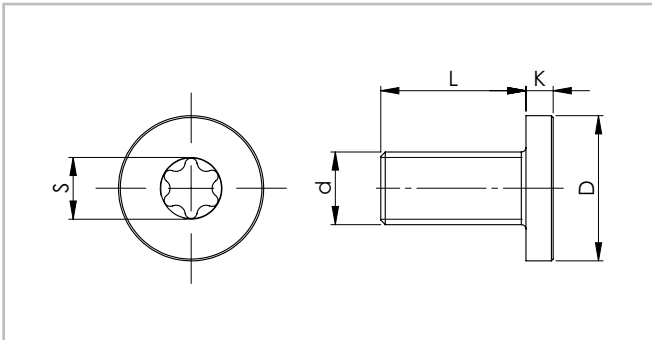

Fig. 40

The DRT 43 roller telescopic must be fixed with a custom design of Torx® screws with low cap head. The screws are included in the scope of supply. All other rails are fixed with counter-sunk or cap head screws as per DIN 7991 or 7984. In size 63 of the ASN and DMS series, Torx® screws with low head cap screws are available on request (see fig. 40).

Size	Screw type	d	D [mm]	L [mm]	K [mm]	S
63	M8 x 20	M8 x 1.25	13	20	5	T40
43	M8 x 16	M8 x 1.25	16	16	3	

Tab. 38

Tightening torques of the standard fixing screws to be used

Property class	Size	Tightening torque [Nm]
10.9	22	4.3
	28	8.5
	35	14.6
	43	34.7
	63	34.7

Tab. 39

Installation instructions

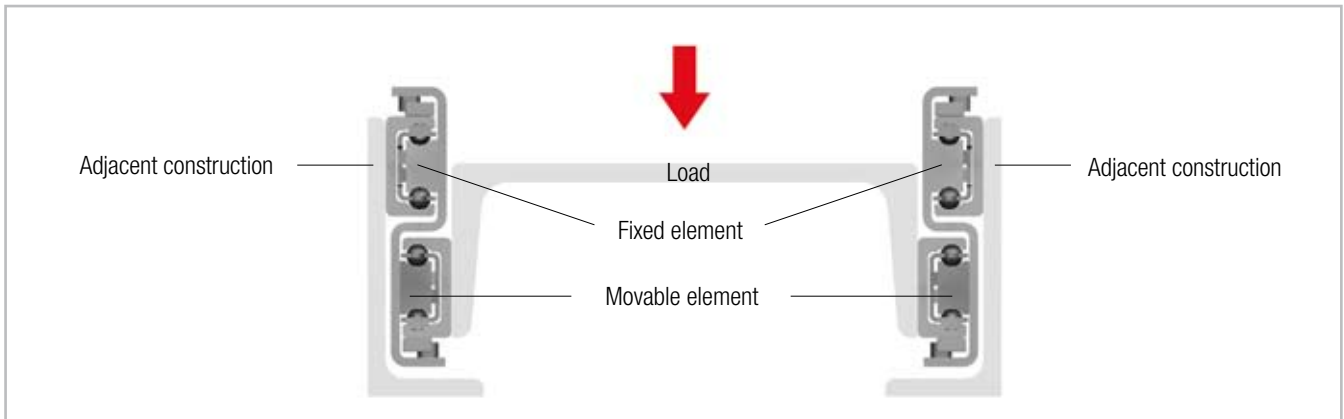

Fig. 41

General

- Internal stops are used to stop the unloaded slider and the ball cage. Please use external stops as end stops for a loaded system.
- To achieve optimum running properties, high service life and rigidity, it is necessary to fix the telescopic rails with all accessible holes on a rigid and level surface. When using two telescopic rails, please observe the parallelism of the installation surfaces. The fixed and movable rails fit to the rigid assembly construction.
- Telescopic Rail guides are suitable for continuous use in automatic systems. For this, the stroke should remain constant in all moving cycles and the operating speed must be checked (see pg. 35, fig. 39).
The movement of the telescopic rails is enabled by internal ballcages, which could experience an offset from the original position with differing strokes. This phase offset can have a negative effect on the running properties or limit the stroke. If differing strokes occur in an application, the drive force must be sufficiently dimensioned in order to appropriately synchronise the ballcage offset. Otherwise, an additional maximum stroke must be planned regularly to ensure the correct position of the ballcage.

ASN

- Series ASN accepts radial and axial loads and moments in all principle directions.
- Horizontal and vertical application is possible. Prior to vertical installation, we recommend a check by application technology.
- The installation of two partial extensions on a profile provides a load capable full extension. For individual solutions, please contact Application Technology.

DE / DBN

- Series DE and DBN accept radial and axial loads.
- Horizontal and vertical application is possible. Prior to vertical installation, we recommend a check by application technology.
- The functionality of custom design DE...D is only guaranteed if the stroke available is completely used.

DS / LTF / DMS / DRT

- Series DS, LTF, DMS and DRT accept radial loads. This should act in the vertical cross-sectional axis on the movable rails.
- Horizontal and vertical application is possible. Prior to vertical installation, we recommend a check by application technology.
- When installing make sure that the load is placed on the movable element (the lower rail) (see fig. 41).
The opposite assembly negatively affects the function.
- Installation must be done on a rigid adjacent construction using all accessible fixing holes.
- Pay attention to the parallel alignment during assembly with paired application.

Portfolio

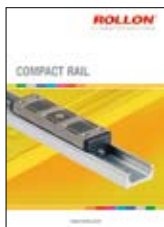

COMPACT RAIL

Rugged roller sliders with innovative self adjustment



MONO RAIL

Profile guideways for highest degrees of precision



CURVILINE

Curvilinear rails for constant and variable radii



MINIATURE MONO RAIL

Miniature format profile guideways with unique ball design

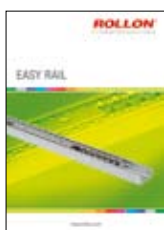

EASY RAIL

Compact, versatile linear bearings



X-RAIL

Roller embossed stainless steel profiles for the use in rough environments



UNILINE

Steel-reinforced, belt-driven linear actuators with hardened steel linear bearings and precision radial ball bearing rollers

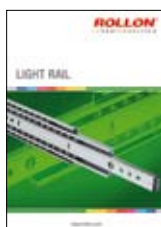

LIGHT RAIL

Full and partial extension, lightweight drawer slides

Ordering key

Telescopic rails

DSB	28	690	885	L	NIC
					Expanded surface protection is deviation from standard (ISO 2081) <i>see pg. 36, Anticorrosive protection</i>
					Right (R) or left (L) version (only for series DSB, DMS, DRT) <i>see pg. 7 Remarks</i>
					Stroke, if deviating from standard stroke (catalogue data) <i>see pg. 8ff Product dimensions and Ordering key for special strokes</i>
					Length <i>see pg. 8ff Product dimensions</i>
					Size <i>see pg. 8ff Product dimensions</i>
					Product type <i>see pg. 8ff Product dimensions</i>

Ordering example 1: ASN35-0770

Ordering example 2: DSB28-0690-0885-L-NIC

Notes on ordering: Information for right and left side installation and for expanded surface protection is only necessary if required.

Rail lengths and strokes are always stated with 4 digits. Please use zeroes to fill in for lengths with less than 4 digits

Special strokes

Special strokes are defined as deviations from standard stroke H. They are each available as multiples of the values in tab. 40 and 41.

These values are dependent on the spacing of the ballcage.

Type	Size	Stroke modification [mm]
ASN	22	7.5
	28	9.5
	35	12
	43	15
	63	20

Tab. 40

Type	Size	Stroke modification [mm]
DSS DE DBN	22	15
	28	19
	35	24
	43	30
	63	40

Tab. 41

Stroke modification of series DMS on request.

No stroke modification is possible for series DSD and DRT. Each stroke modification influences the load capacities stated in the catalogue. It can happen that after a stroke modification important fastening holes are no longer accessible. For more information please contact Application Technology.

Fold out ordering key

To make this product catalog as simple as possible for you to use, we have included the following easy-to-read chart.

Your advantages:

- Description and ordering designations easy to read at one glance
- Simplified selection of the correct product
- Links to detailed descriptions in the catalog



Italy

ROLLON S.r.l.

Via Trieste 26
I-20059 Vimercate (MB)
Tel.: (+39) 039 62 59 1
Fax: (+39) 039 62 59 205
E-Mail: infocom@rollon.it
www.rollon.it

Germany

ROLLON GmbH

Voisweg 5c
D-40878 Ratingen
Tel.: (+49) 21 02 87 45 0
Fax: (+49) 21 02 87 45 10
E-Mail: info@rollon.de
www.rollon.de

France

ROLLON S.A.R.L.

Les Jardins d'Eole, 2 allée des Séquoias
F-69760 Limonest
Tel.: (+33) (0)4 74 71 93 30
Fax: (+33) (0)4 74 71 95 31
E-Mail: infocom@rollon.fr
www.rollon.fr

Netherlands

ROLLON B.V.

Edisonstraat 32b
NL-6902 PK Zevenaar
Tel.: (+31) 31 65 8 19 99
Fax: (+31) 31 63 4 12 36
E-Mail: info@rollon.nl
www.rollon.nl

USA

ROLLON Corporation

30A Wilson Drive
Sparta, NJ 07871, USA
Tel.: (+1) 973 300 5492
Fax: (+1) 973 300 9030
E-Mail: info@rolloncorp.com
www.rolloncorp.com

All addresses of our global sales partners can also
be found in the internet at www.rollon.com